

INSTRUCTION AND MAINTENANCE MANUAL BUTTERFLY VALVES TYPE 2236/2246

These instructions must be stored and consulted by installers and by personnel doing routine and extraordinary maintenance.

- Before installation or maintenance, cut out the line upstream and downstream of the valve and make sure there is no pressure.
- Never exceed the maximum pressure and temperature limits marked on the valve.
- The product must not be modified: any tampering could make the device dangerous.
- The manufacturer will not be liable if the product is used improperly. Installation and maintenance must be performed by specialised personnel.
- This product must be used only for its specific intended purpose: any other use is potentially dangerous. The manufacturer will in no case be considered liable for any damage deriving from improper use.
- If the liner becomes damaged, have it replaced immediately by qualified personnel.

GENERAL INSTRUCTIONS

- Before shipment, the surfaces of the liners are lubricated with silicone grease and/or oil.
- If the liner and disc have to be silicone-free for specific uses (for example, hydrogen, oxygen, chlorine, etc.), the silicone can be removed with appropriate solvents or other suitable cleaning and degreasing products.
- Before installing the valve, clean all dirt and welding residue from the piping to prevent damage to the body seat.
- Make sure that the piping is current-free. If there is any stray current, equip the valve with an antistatic device.
- Do not use the valve as a lever to widen the flanges: this may result in damage to the seat during installation or operation.
- When installing on a new system, use the valve as a spacing element. Spot-weld the flange and piping and, before completing the weld, remove the bolts and valve. **Do not complete welding of the flanges to the piping with the valve bolted between the flanges: this will cause serious heat damage to the seat.**
- On the butterfly valves there is a marking with data that allow to identify the product and the operational conditions.
- On the marking there is moreover the marking of conformity CE and, for butterfly valves in explosive atmosphere, the specific marking  in accordance with con la Directive 94/9/EC (ATEX).

Only for valves marked according to Directive 94/9/EC (ATEX)

The valves marked according to Directive 94/9/EC (ATEX) are devices designed to be used in accordance with the operational parameters established, even in potentially explosive atmospheres caused by mixtures of air and gases, vapours, mists or dusts.

The valves have to be used in atmosphere having temperature from -20°C to +60°C [UNI EN 13463-1:2009].

CLASSIFICATION AND ZONES OF USE

Group	II
Category	2
Zone	1 21
Type of atmosphere	Gases Dusts
Protection	Construction safety "c"
Maximum surface temperature	TX

Zone 1 (gases) & 21 (dusts): explosive atmosphere may occur occasionally in normal operating conditions.

CAUTION: valves are NOT intended to function in places where an explosive atmosphere is present always, often or for long periods (zone 0).

Note on the maximum surface temperature: it does not depend on the valve, but only on the operating conditions related to the fluid transported. The valve itself is therefore NOT to be considered as a source of ignition. The user should consider this technical aspect

and take appropriate countermeasures.

In case the valve (and the pipe) is "thermally insulated" the installer should indicate the appropriate waiting time from plant shutdown, before proceeding with the removal of the insulation.

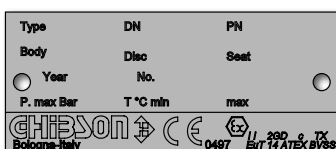

Marking

The user must determine whether the fluid intercepted can cause electrostatic charge. There shall be no occurrence of adiabatic compression and shock waves: it is the user's responsibility to consider such risk and include the necessary measures/devices to prevent this eventuality.

STORAGE

Valves with rubber gasket

If the valves are not installed immediately, they should be stored in a closed, clean and dry room. The valves are packed in boxes to make storage easier. If the valve remains in the warehouse for a long time, or connected to the piping for an extended period without being used, it is advisable to leave the disk halfway open and apply a suitable lubricant (vegetable oil for EPDM; silicone grease for all others) to the elastomer seats.

Valves with PTFE gasket

If the valves are not installed immediately, they should be stored in a closed, clean and dry room. The valves are packed in boxes to make storage easier. If the valve remains in the warehouse for a long time, or connected to the piping for an extended period without being used, it is advisable to leave the disk halfway open and then open and close it several times before installation.

INSTALLATION INSTRUCTIONS

Assembly

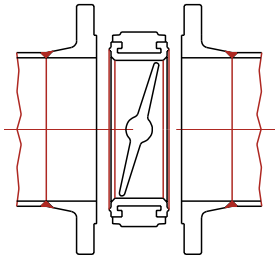

Leave enough space between the flanges for the valve to be easily inserted and removed.
WARNING: to avoid that the gasket goes out of its seat

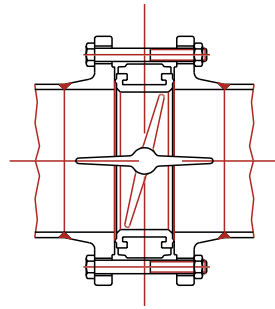

Open the valve completely before tightening the flanges.

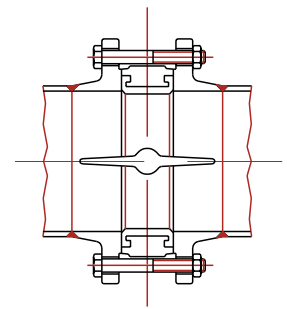

Tighten the bolts until the flanges make contact with the valve body. To prevent leaks, the bolts must be cross-tightened by applying an adequate torque.
NOTE: to avoid leakage of fluid

CORRECT

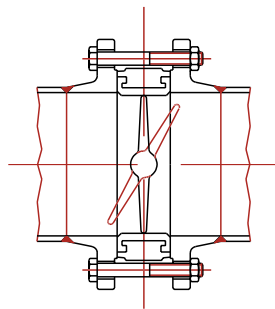

INCORRECT

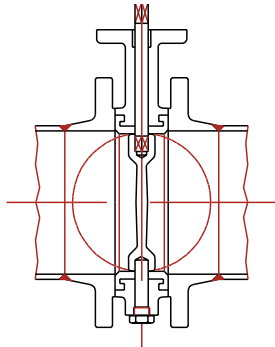

In case of use with muddy fluids, install the valve with horizontal rotation axis so that sediment will flow freely when the valve is opened. This type of assembly is always advisable with valve diameters larger than DN400.

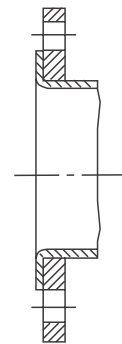

WARNING: on a pipe as shown it's possible to assemble only butterfly valve type BVKA-BLKA-BVKX-BLKX.

GROUNDING PLATE (where foreseen)

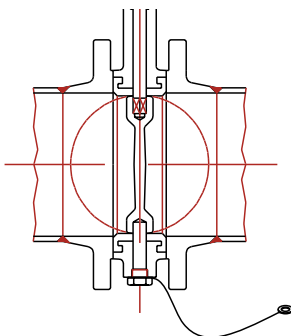

The ground cable have to be protected. The connection to the round have to be make with welding, bolt or other efficient system.

ERROR TO BE AVOIDED

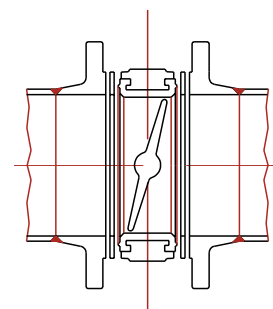

Do not insert other gaskets between valve and flanges.

MAINTENANCE

Maintenance valves type: **BVKI-BVPD-BLKI-BLPD-BFKI**
BVKA-BLKA

DN 040-300
DN 050-150

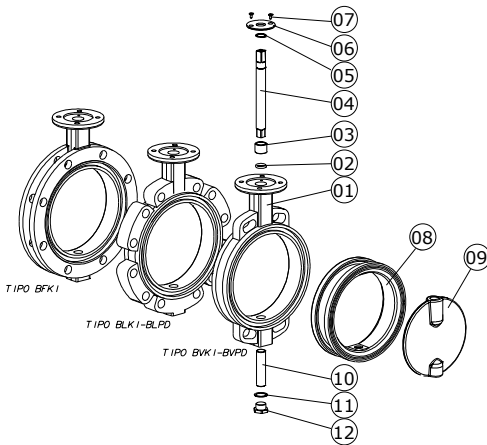

DISASSEMBLY

- Cut out the line upstream and downstream of the valve to be repaired and make sure there is no pressure.
- Close the valve almost completely, then loosen and remove the stay bolts. With appropriate tools, widen the flanges and remove the valve.
- Disassemble the operator (lever with positioner disc or actuator) from the upper flange of the valve body.
- Unscrew lower plug 12 and remove lower shaft 10 by means of its threaded hole.
- Remove flange 6 by removing screws 7.
- With an extractor, remove upper shaft 4 by means of its threaded hole. Remove bushing 3 and O-ring 2.
- Remove disc 9, using a rubber mallet if necessary. Be very careful not to damage the disc profile.
- Remove liner 8 using a large screwdriver to pry it out of the body.

ASSEMBLY

- Replace O-ring 2 and, if necessary, bushing 3.
- Lock upper shaft 4 in a vice so that it extends 10-15 mm internally when body 1 is placed on it.
- Insert new liner 8 on the extending part of the shaft and assemble it on the body with the screwdriver.
- Set the square hole of disc 9 on the extending part of the shaft, then push until the opposite hole mates with the through hole of the lower shaft (use a rubber mallet).
- Insert lower shaft 10, then replace plug 12 and packing 11.
- Position shaft 4, paying attention that the end square inserts perfectly in the disc and that the notch on the opposite plane is parallel to the disc position.
- Assemble flange 6.
- Reassemble the operator.

Maintenance valves type: **BVKI-BVPD-BLKI-BLPD-BFKI**

DN 350-500

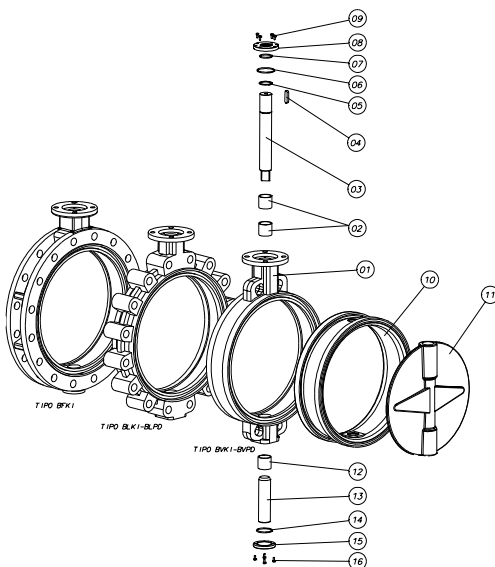

DISASSEMBLY

- Cut out the line upstream and downstream of the valve to be repaired and make sure there is no pressure.
- Close the valve almost completely, then loosen and remove the stay bolts. With appropriate tools, widen the flanges and remove the valve.
- Disassemble the operator (lever with positioner disc or actuator) from the upper flange of the valve body.
- Unscrew lower plug 12 and remove lower shaft 10 by means of its threaded hole.
- Remove flange 6 by removing screws 7.
- With an extractor, remove upper shaft 4 by means of its threaded hole. Remove bushing 3 and O-ring 2.
- Remove disc 9, using a rubber mallet if necessary. Be very careful not to damage the disc profile.
- Remove liner 8 using a large screwdriver to pry it out of the body.

ASSEMBLY

- Replace O-ring 2 and, if necessary, bushing 3.
- Lock upper shaft 4 in a vice so that it extends 10-15 mm internally when body 1 is placed on it.
- Insert new liner 8 on the extending part of the shaft and assemble it on the body with the screwdriver.
- Set the square hole of disc 9 on the extending part of the shaft, then push until the opposite hole mates with the through hole of the lower shaft (use a rubber mallet).
- Insert lower shaft 10, then replace plug 12 and packing 11.
- Position shaft 4, paying attention that the end square inserts perfectly in the disc and that the notch on the opposite plane is parallel to the disc position.
- Assemble flange 6.
- Reassemble the operator.

Maintenance valves type: **BVKX-BLXX**

DN 050-100

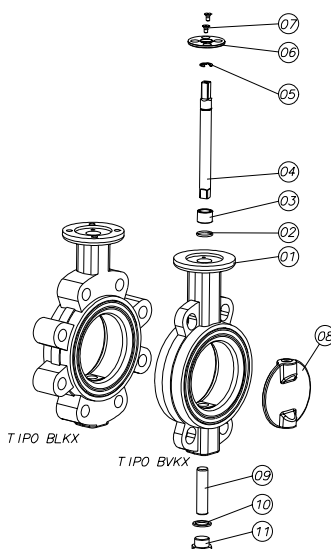

DISASSEMBLY

- Cut out the line upstream and downstream of the valve to be repaired and make sure there is no pressure.
- Close the valve almost completely, then loosen and remove the stay bolts. With appropriate tools, widen the flanges and remove the valve.
- Disassemble the operator (lever with positioner disc or actuator) from the upper flange of the valve body.
- Unscrew lower plug 11 and remove lower shaft 9 by means of its threaded hole.
- Remove flange 6 by removing screws 7.
- With an extractor, remove upper shaft 4 by means of its threaded hole. Remove bushing 3 and O-ring 2.
- Remove disc 8, using a rubber mallet if necessary. Be very careful not to damage the disc profile.

ASSEMBLY

- Replace O-ring 2 and, if necessary, bushing 3.
- Lock upper shaft 4 in a vice so that it extends 10-15 mm internally when body 1 is placed on it.
- Set the square hole of disc 8 on the extending part of the shaft, then push until the opposite hole mates with the through hole of the lower shaft (use a rubber mallet).
- Insert lower shaft 9, then replace plug 11 and packing 10.
- Position shaft 4, paying attention that the end square inserts perfectly in the disc and that the notch on the opposite plane is parallel to the disc position.
- Assemble flange 6.
- Reassemble the operator.

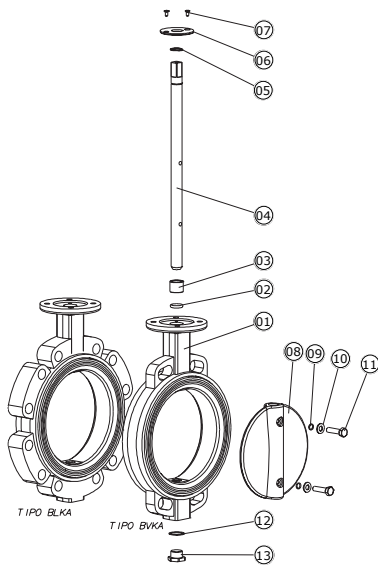
**Maintenance valves type: BVKA-BLKA
BVKX-BLKX**

DISASSEMBLY

- Cut out the line upstream and downstream of the valve to be repaired and make sure there is no pressure.
- Close the valve almost completely, then loosen and remove the stay bolts. With appropriate tools, widen the flanges and remove the valve.
- Disassemble the operator (lever with positioner disc or actuator) from the upper flange of the valve body.
- Unscrew lower plug 13 and remove flange 6 by removing screws 7.
- Unscrew and remove screws 11 with O-rings 9 and washers 10.
- With an extractor, remove upper shaft 4 by means of its threaded hole. Remove bushing 3 and O-ring 2.
- Remove disc 8, using a rubber mallet if necessary. Be very careful not to damage the disc profile.
- Because the liner is vulcanised to the valve body, either replace the entire vulcanised body or send it to DVC for new vulcanising.

**DN 200-300
DN 125-250**
ASSEMBLY

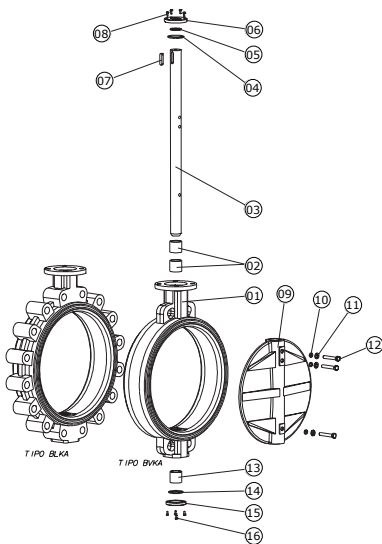
- Replace O-ring 2 and, if necessary, bushing 3.
- Insert a guide shaft (the same diameter as shaft 4) into the lower hole of the body so that it extends 15/20 mm from the bushing plane (the extending part of the shaft must be chamfered like the end of shaft 4).
- Insert disc 8 on the extending part of the shaft, then push until the opposite hole mates with the through hole of the upper shaft.
- Insert shaft 4 until the holes on it mate with those on the disc.
- Reassemble screws 11, replacing O-rings 9 if necessary. Replace and reassemble plug 13 and O-ring 12.
- Assemble flange 6.
- Reassemble the operator.

Maintenance valves type: BVKA-BLKA

DISASSEMBLY

- Cut out the line upstream and downstream of the valve to be repaired and make sure there is no pressure.
- Close the valve almost completely, then loosen and remove the stay bolts. With appropriate tools, widen the flanges and remove the valve.
- Disassemble the operator from the upper flange of the valve body and remove key 7 from shaft 3.
- Unscrew screws 16 and 8. Remove lower flange 15 and upper flange 6.
- Unscrew and remove screws 12 with O-rings 10 and washers 11.
- With an extractor, remove upper shaft 3 by means of its threaded hole.
- Remove disc 9 with an appropriate tool (press with hydraulic piston). Be very careful not to damage the disc profile.
- Because the liner is vulcanised to the valve body, either replace the entire vulcanised body or send it to DVC for new vulcanising.

DN 350-500
ASSEMBLY

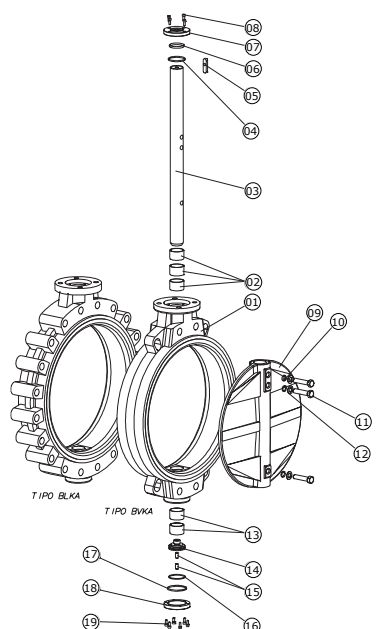
- Replace bushings 2 and 13 if necessary.
- Set the valve body on the press and insert a guide shaft (the same diameter as shaft 3) into the lower hole of the body so that it extends 20/30 mm from the bushing plane (the extending part of the shaft must be chamfered like the end of shaft 3).
- Insert disc 9 on the extending part of the shaft, then push until the opposite hole mates with the through hole of the upper shaft (use the press piston).
- Insert shaft 3 until the holes on it mate with those on the disc.
- Reassemble screws 12, replacing O-rings 10 if necessary.
- Assemble flange 15 and replace O-ring 14 if necessary.
- Assemble flange 6 and replace O-ring

Maintenance valves type: BVKI-BVKA-BLKI-BLKA-BFKI

DISASSEMBLY

- Cut out the line upstream and downstream of the valve to be repaired and make sure there is no pressure.
- Close the valve almost completely, then loosen and remove the stay bolts. With appropriate tools, widen the flanges and remove the valve.
- Disassemble the operator from the upper flange of the valve body and remove key 5 from shaft 3.
- Unscrew screws 19. Remove lower flange 18, unscrew screws 15 and unscrew support register 14 with a hook spanner.
- Remove flange 7 by removing screws 8.
- Unscrew and remove screws 11 with O-rings 10 and washers 12.
- With an extractor, remove upper shaft 3 by means of its threaded hole.
- Remove disc 9 with an appropriate tool (press with hydraulic piston). Be very careful not to damage the disc profile.
- Because the O-ring is vulcanised to the valve body, either replace the entire vulcanised body or send it to DVC for new vulcanising.

DN 600-800
ASSEMBLY

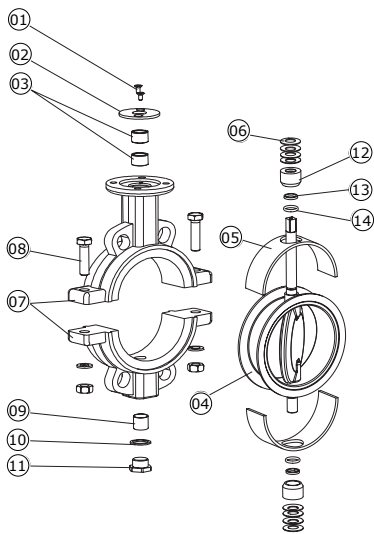
- Replace bushings 2 and 13 if necessary.
- Set the valve body on the press and insert a guide shaft (the same diameter as shaft 3) into the lower hole of the body so that it extends 20/30 mm from the bushing plane (the extending part of the shaft must be chamfered like the end of shaft 3).
- Insert disc 9 on the extending part of the shaft, then push until the opposite hole mates with the through hole of the upper shaft (use the press piston).
- Insert shaft 3 until the holes on it mate with those on the disc.
- Reassemble screws 11, replacing O-rings 10 if necessary.
- Replace O-ring 16 if necessary. Screw support register 14 fully down, then unscrew it 1/2 turn. Lock it in this position with socket-head screws 15.
- Assemble flange 18 and replace O-ring 17 if necessary.
- Assemble flange 7 and replace O-rings 4 and 6 if necessary.
- Reassemble key 5 and the operator.

Maintenance valves type: BVTT - BLTT
DN050-300

DISASSEMBLY

- Cut out the line upstream and downstream of the valve to be repaired and make sure there is no pressure.
- Close the valve almost completely, then loosen and remove the stay bolts. With appropriate tools, widen the flanges and remove the valve.
- Disassemble the operator from the upper flange of the valve body
- Remove flange 2.
- Unscrew screws 8, open body 7 in two parts, and remove disc-liner-shaft 4 and elastic support 5.
- Remove springs 6, support 12 and o-ring 13,14.

ASSEMBLY

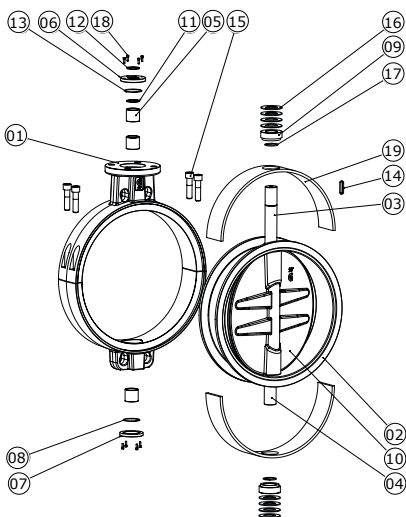
- Position new elastic support 5 disc-liner-shaft 4 and, if necessary, replace bush 3.
- Assemble outside elastic support 5, new o-ring 13-14, support 12 and springs 6.
- Insert the group in half-bodies 7.
- Partially close disc, then tighten the half-bodies with screws 8.
- Assemble bush 3 and flange 2.
- Reassemble the operator

Maintenance valves type: BVTT - BLTT
DN050-300

DISASSEMBLY

- Cut out the line upstream and downstream of the valve to be repaired and make sure there is no pressure.
- Close the valve almost completely, then loosen and remove the stay bolts. With appropriate tools, widen the flanges and remove the valve.
- Disassemble the operator from the upper flange of the valve body.
- Unscrew screws 18, remove the flange 6 e 7.
- Unscrew screws 15, open the body 1 in two parts and remove the disc 10, liner 2, shafts 3 e 4, elastic bases 19.
- Remove the springs 16, pressure bushings 9 and the O-Rings 11,13,17.

ASSEMBLY

- Replace elastic bases 19 upon the disc 10, liner 2, shafts 3 e 4 replace the bushings if necessary 5.
- Insert new O-Rings 11,13,17, the housing 9 and the springs 16.
- Insert all groups inside the two parts of the body 1.
- Having almost closed the two parts of the body, close those with the screws 15.
- Replace the bushes 5 and the flange 6,7.
- Replace the screws 18.
- Reassemble the operator.